

6801 132nd Place S.E.  
Newcastle, Washington 98059-3088  
(425) 235-9200 Fax (425) 228-7429

BOARD OF COMMISSIONERS

Richard D. Anderson  
Douglas C. Kunkel  
Pamela A. Martin

GENERAL MANAGER  
Robert O. Russell

OFFICE MANAGER  
Pamela S. Nelson

After device has been installed and tested by a certified tester, contact Coal Creek Utility District for final inspection.

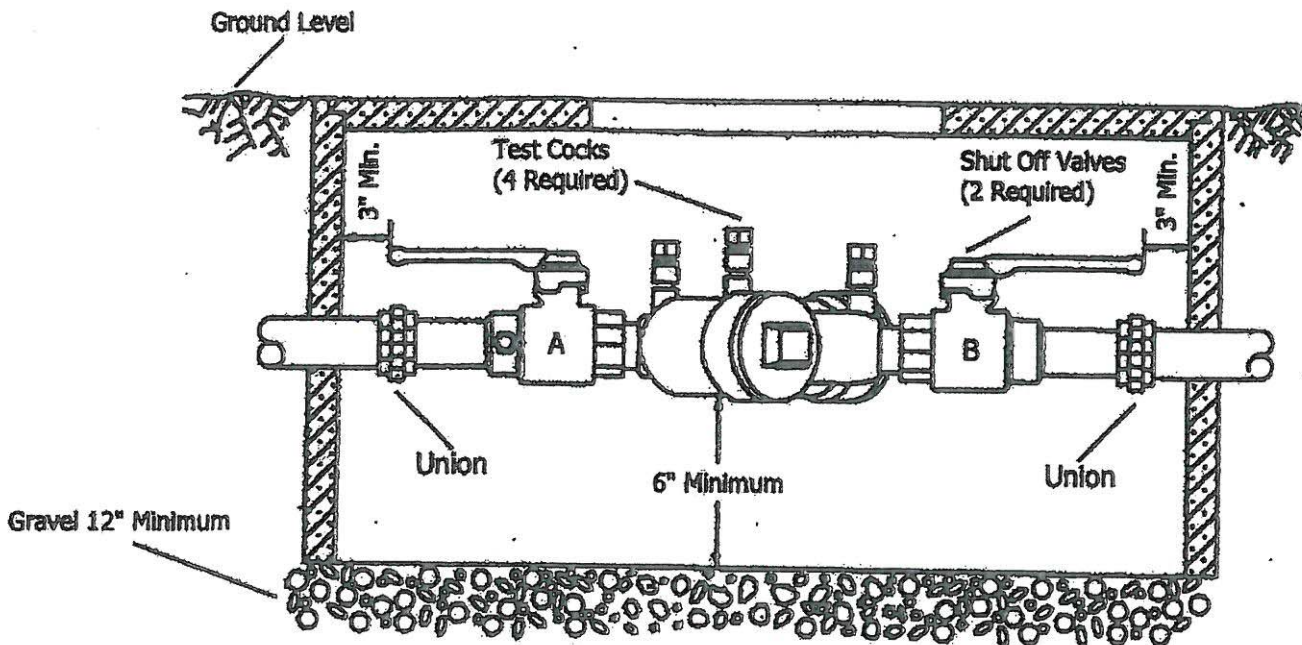
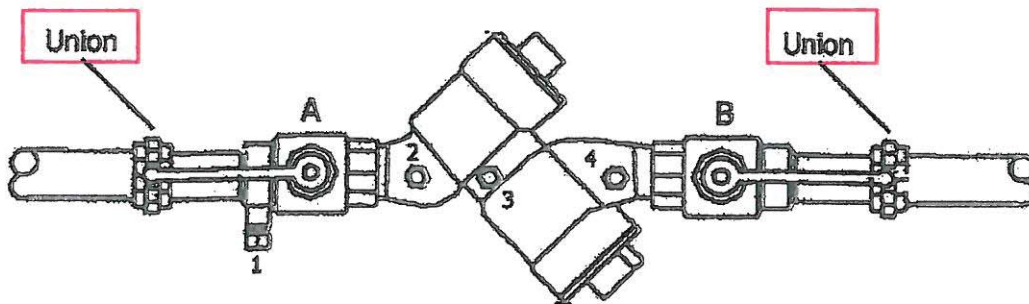

MINIMUM CLEARANCE FOR SMALL SIZE DCVA IN BELOW-GROUND BOX.

**INLET AND OUTLET UNIONS ARE RECOMMENDED ON ALL HORIZONTAL AND VERTICAL INSTALLATIONS UP TO 3". UNIONS MUST BE VISIBLE INSIDE THE BOX**